



**Please follow the instruction and use carefully!**  
**This appliance produces hot steam!**

### Safety Instructions

1. Ensure that the power supply voltage corresponds to that shown on the appliance.
2. Do not place the appliance near heat or in a hot oven, as serious damage could result.
3. Never leave the appliance in operation unattended. Keep away from children.
4. Do not use the appliance if the appliance or the cord is damaged, the appliance has fallen over, shows visible damage, or does not work properly.
5. If the power cord is damaged, it must be replaced by the manufacturer, a service agent, or similarly qualified persons in order to avoid a hazard.
6. Burns can occur by touching the hot surface of the appliance, hot water, steam or hot food.
7. Never immerse the appliance in water!
8. Do not move the appliance when it is full of liquid or hot foods.
9. Do not touch the appliance when it is steaming; use oven mitts to remove the lid, rice bowl, and/or steamer baskets.
10. Always unplug the appliance immediately after use, when moving it or prior to any cleaning or maintenance.

### Specifications

Model	RHST-15001
Dimensions (L x W x H)	12.2" x 9.25" x 15.63"
Capacity	9.5 Quart (9 L)
Voltage	120 V
Watts	800 W
Cord Length	24"
Weight	4.59 lb
Color	White
Material	Plastic



Explore more at [Rosewill.com](http://Rosewill.com).



Technical Support Information [techsupport@rosewill.com](mailto:techsupport@rosewill.com) 1-800-575-9885  
Please register your product at [www.rosewill.com](http://www.rosewill.com) for complete warranty information and support for your product.



RHST-15001\_E



RHST-15001

Thank you for purchasing a Rosewill Food Steamer.  
Please read the instruction manual before use and retain for future reference.

### Parts List

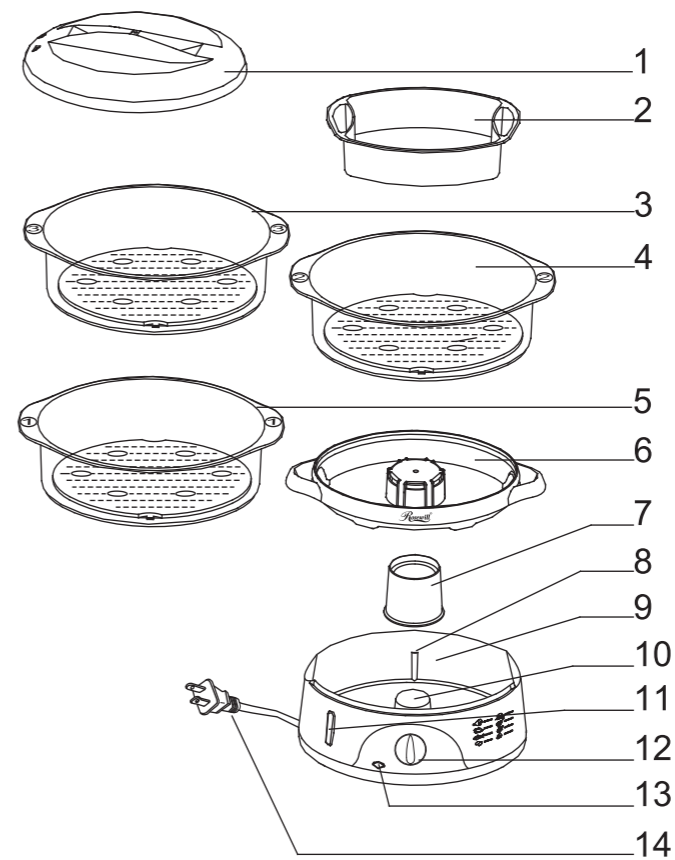

- |                            |                                    |
|----------------------------|------------------------------------|
| 1. Lid                     | 8. Max. water level                |
| 2. Rice bowl (1L capacity) | 9. Water tank                      |
| 3. Steamer basket No. 3    | 10. Heating element                |
| 4. Steamer basket No. 2    | 11. Exterior water level indicator |
| 5. Steamer basket No. 1    | 12. 60-minute timer                |
| 6. Juice collector         | 13. Power indicator light          |
| 7. Removable turbo ring    | 14. Power cord                     |

**Note:**  
Steam trays, rice bowl tray and top lid are all dishwasher safe and BPA free.

### Instruction For Use

1. Using warm water and mild dish soap, wash all the removable parts and the inside of the water tank, then rinse and dry.
2. Place the base unit on a stable surface, put the turbo ring around the heating element (the larger side on the bottom).
3. Pour fresh water directly into the water tank up to the maximum level.
4. Place the juice collector on the top of the water tank.
5. Place the food in the center of baskets.
6. Place the baskets on the top of the juice collector, and put the lid on.
7. Plug in and set the timer to the recommended cooking time (see table of cooking times). The indicator light will turn on indicating the cooking has begun.
8. Check the water level with the exterior water level indicator, and if necessary, add water from the side of juice collector during cooking.
9. The timer will ring and the indicator light will turn off automatically when done.
10. You can reheat food carefully as long as there is water in the tank.
11. Remove the lid, place the basket(s) on a plate.
12. Unplug the appliance, let it cool completely before cleaning.

### Cleaning And Maintenance

1. Empty the water tank and clean it with a damp cloth.
2. All other removable parts can be put in the dishwasher.
3. Descale the appliance after every 8 uses.
4. To descale the unit, position the turbo ring upside down around the heating element (the larger side up). Fill the water tank with cold water to "MAX" line, fill the inside of the turbo ring with white vinegar to the same level. Do not heat up (to avoid the descaling odor). Leave overnight to descale. Rinse out the inside of water tank with warm water several times.
5. Stack basket No. 1 onto No. 2, then together onto No. 3. Put the rice bowl into steamer basket No. 1. Place baskets on the juice collector and place lid on top.

### Cooking Chart

Vegetables	Quantity	Approx. cooking time
Asparagus	1 bunch	5-10 minutes
Beetroot	17.6 oz	30-10 minutes
Beans	17.6 oz	10-15 minutes
Broccoli	17.6 oz	10-16 minutes
Cauliflower	17.6 oz	12-18 minutes
Carrots (Sliced)	17.6 oz	15-20 minutes
Corn	3-5 cobs	10-20 minutes
Corn, baby	17.6 oz	10-15 minutes
Greens (bok choy, spinach, etc.)	17.6 oz	5-10 minutes
Parsnip	17.6 oz	10-15 minutes
Potatoes (quartered)	17.6 oz	25-30 minutes
Pumpkin (sliced)	17.6 oz	20-25 minutes
Snow Peas	8.8 oz	5-7 minutes
Sweet Potatoes (sliced)	17.6 oz	15-20 minutes

Meat	Quantity	Approx. cooking time
Chicken (In foil)	1 breast fillet	20-25 minutes
Fish (In foil)	1 fish fillet/cutlet	15-20 minutes
Prawns	14 oz	6-8 minutes

Rice	Cups	Approx. cooking time
White rice	1 Rice to 1 water	35-40 minutes
Brown rice	1 Rice to 1½ water	55-60 minutes

Oat Porridge	Cups	Approx. cooking time
White rice	½ Rice to 2 water	30-35 minutes
Oatmeal	1 Oatmeal to 1 water or 1 milk	10-20 minutes

Other	Quantity	Approx. cooking time
Eggs Hard Boiled	4	15-20 minutes
Eggs Soft Boiled	4	2-9 minutes
Hot Dogs	8	8-10 minutes
Dim Sum	10	15-20 minutes
Cake	1-3 cake pans	15-20 minutes